

A (2 : 1)
Antrieb

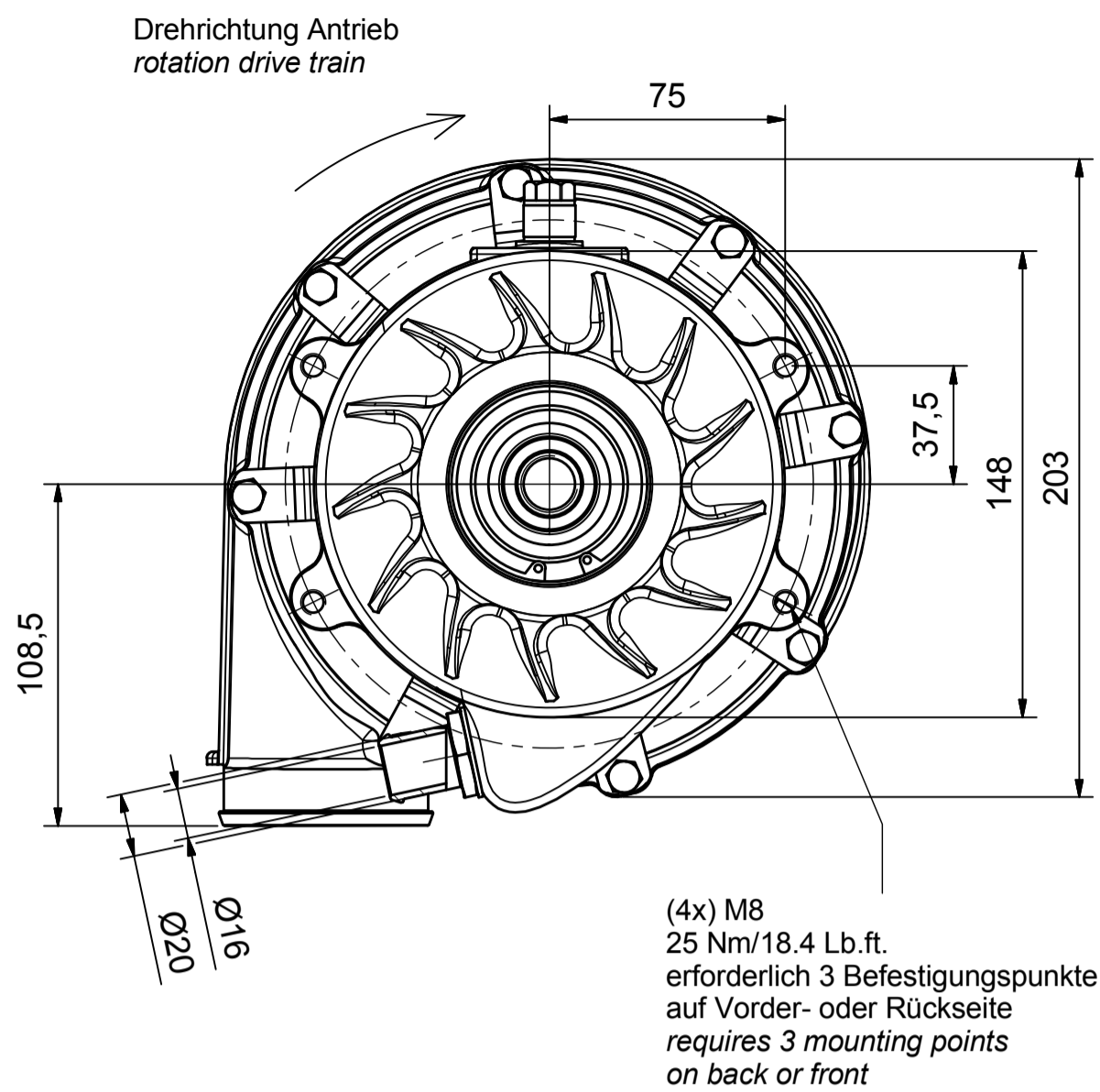

(4x) M8
25 Nm/18.4 Lb.ft.
erforderlich 3 Befestigungspunkte
auf Vorder- oder Rückseite
requires 3 mounting points
on back or front

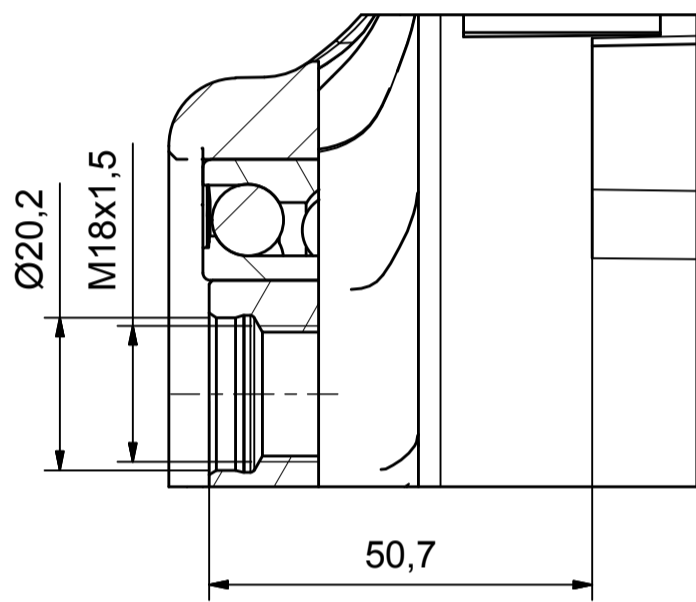
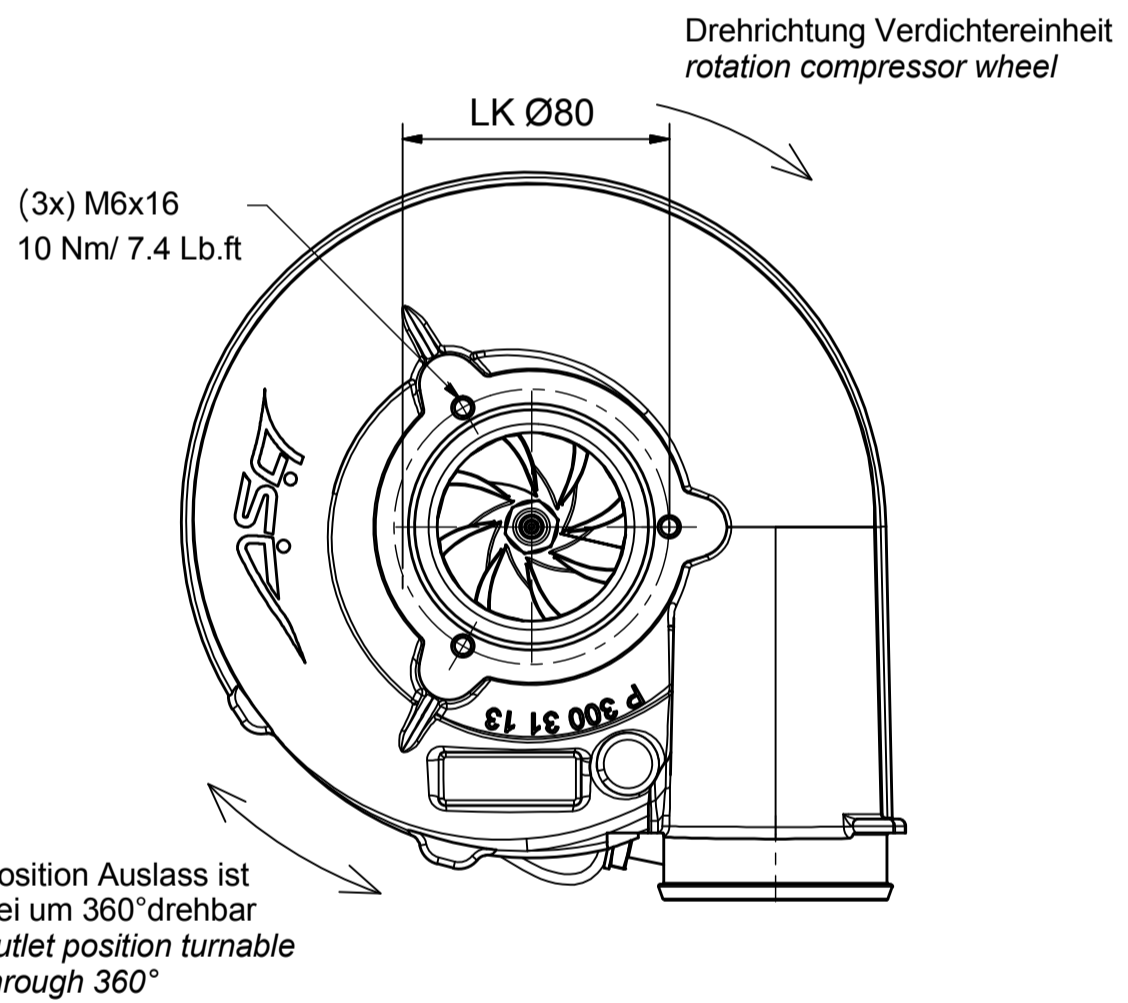

Gewicht mit K05 Kupplung (without pulley/without clutch)	5,5 kg
Innere Übersetzung: (inner gear ratio)	1:15
Ölvolumenstrom (übliche Motorenöle): (oil volume flow-usual engine oil)	1,2-1,6 l/min
Min./Max. Öleintrittstemperatur (min./max. oil inlet temperature)	-40°C/105 °C
Nenn Drehzahl (rpm level)	105.000 1/min
Luftmasse (air mass) max. T1-316	1.530 kg/h
Leistungsbereich (power range)	500 PS
Max. Druckverhältnis p2/p1 (max. pressure ratio)	2.6
Massenträgheitsmoment (mass moment of inertia)	auf Anfrage (on request)

Verdichterkennfeld flow chart T1-316 (3470)

