

# Kompressor T1-313

# Datenblatt data sheet

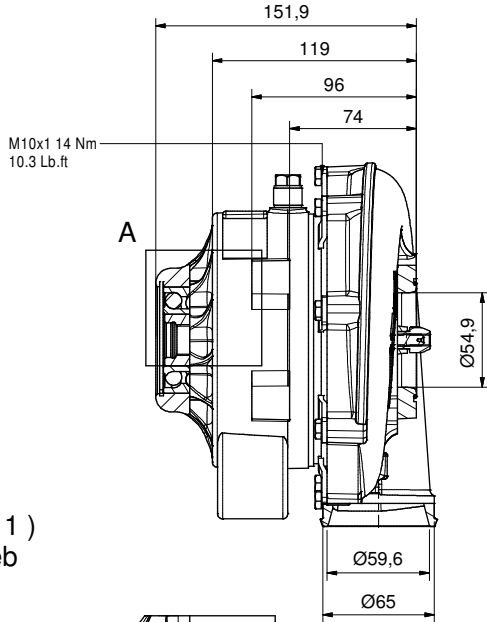

A ( 2 : 1 )  
Antrieb  
drive

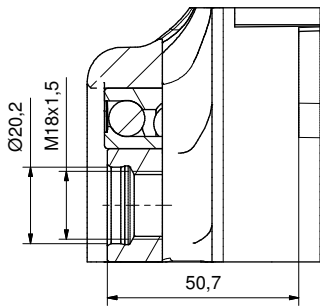

Gewicht ohne Kupplung (mass pulley/without clutch)	5,5 kg
Innere Übersetzung: (inner gear ratio)	1:15
Ölvolumenstrom (übliche Motorenöle): (oil volume flow- usual engine oil)	1,2-1,6 l/min
Min./Max. Öleintrittstemperatur (min./max. oil inlet temperature)	-40°C/105°C
Nenn Drehzahl (rpm level)	105.000 1/min
Luftmasse (air mass) max. T1-313/T1-316	1.270 kg/h
Leistungsbereich (power range)	420 PS
Max. Druckverhältnis p2/p1 (max. pressure ratio)	2.6
Massenträgheitsmoment (mass moment of inertia)	auf Anfrage (on request)

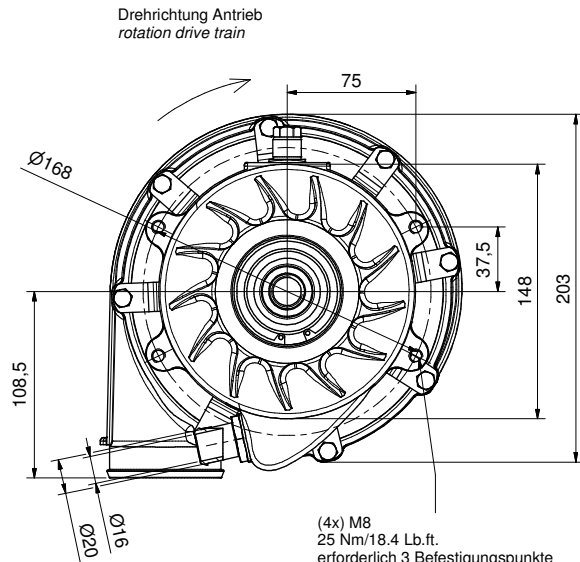

(4x) M8  
25 Nm/18.4 Lb.ft.  
erforderlich 3 Befestigungspunkte  
auf Vorder- oder Rückseite  
requires 3 mounting points  
on back or front

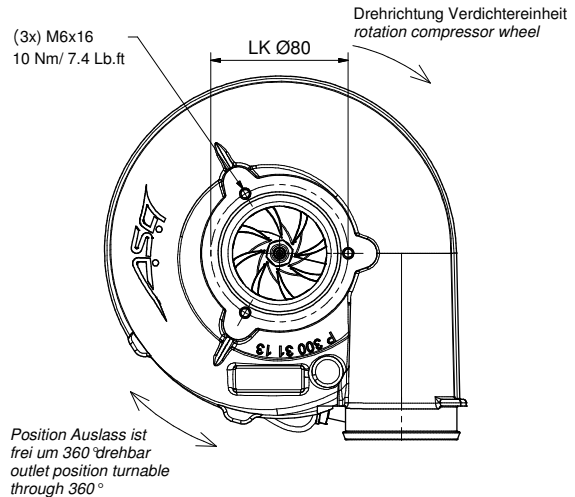

## Verdichterkennfeld flow chart T1-313

